

FICHE TECHNIQUE - SPEC SHEET



INTERMAT
PORTES, ESCALIERS ET BOISERIES

Porte de Masonite / Masonite Door

Modèle / Model

CAMBRIDGE 6'8"

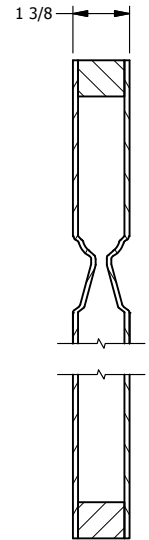
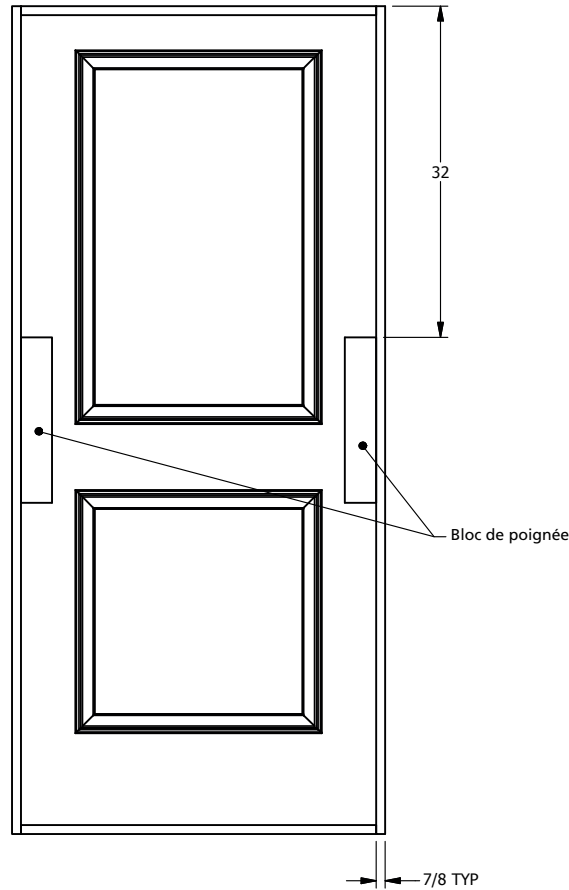
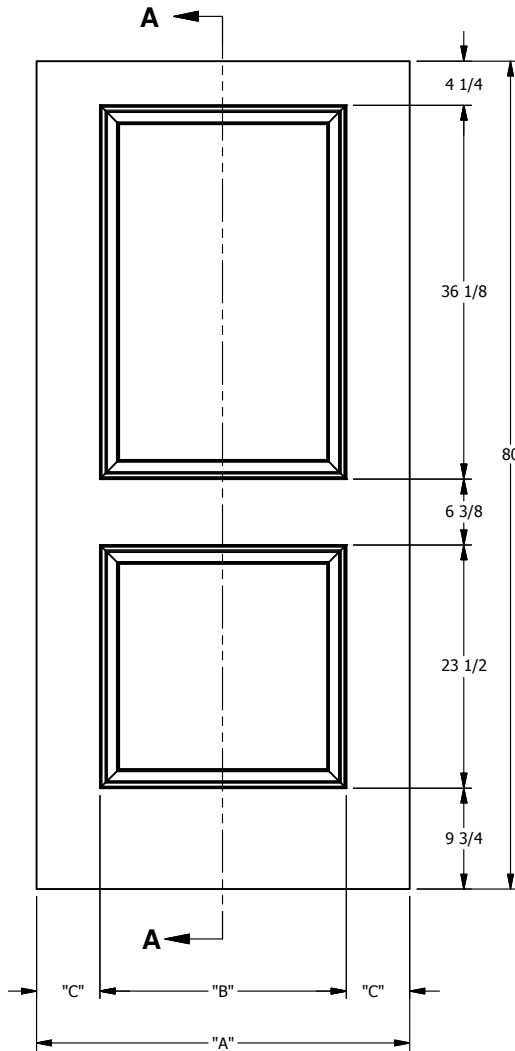

SECTION A-A

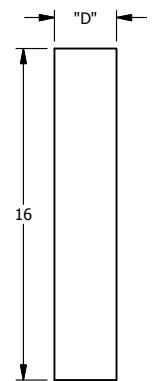

Détail du bloc de poignée

DIMENSIONS				
Dimension des portes	"A"	"B"	"C"	"D"
3'-0" x 6'-8"	36"	23 3/4"	6 1/8"	3"
2'-10" x 6'-8"	34"	23 3/4"	5 1/8"	3"
2'-8" x 6'-8"	32"	21 11/16"	5 5/32"	3"
2'-6" x 6'-8"	30"	19 11/16"	5 5/32"	3"
2'-4" x 6'-8"	28"	17 11/16"	5 5/32"	3"
2'-2" x 6'-8"	26"	17 11/16"	4 5/32"	2 5/8"
2'-0" x 6'-8"	24"	13 11/16"	5 5/32"	3"
1'-10" x 6'-8"	22"	13 11/16"	4 5/32"	2 5/8"
1'-8" x 6'-8"	20"	11 6/16"	4 7/32"	3"
1'-6" x 6'-8"	18"	11 9/16"	3 7/32"	3"
1'-4" x 6'-8"	16"	9 9/16"	3 7/32"	2 5/8"
1'-3" x 6'-8"	15"	8 9/16"	3 7/32"	2 5/8"
1'-2" x 6'-8"	14"	7 9/16"	3 7/32"	2 3/8"
1'-0" x 6'-8"	12"	5 9/16"	3 7/32"	2 3/8"

Profil du panneau :
Moulure en quart de rond



FICHE TECHNIQUE - SPEC SHEET



INTERMAT
PORTES, ESCALIERS ET BOISERIES

Porte de Masonite / Masonite Door

Modèle / Model

CAMBRIDGE 7'

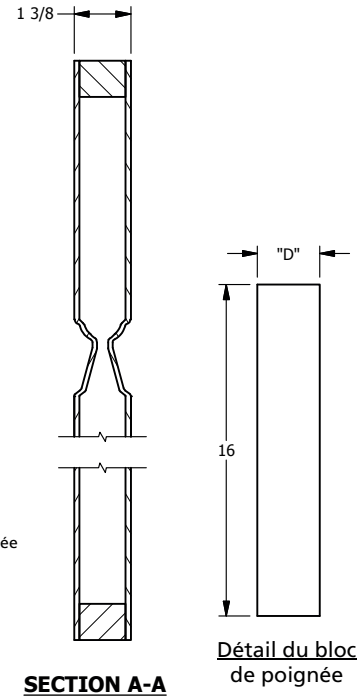
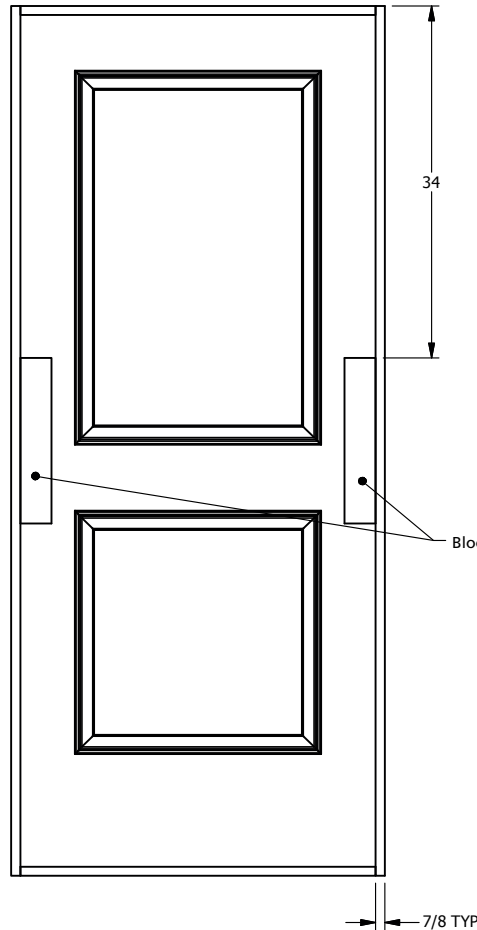
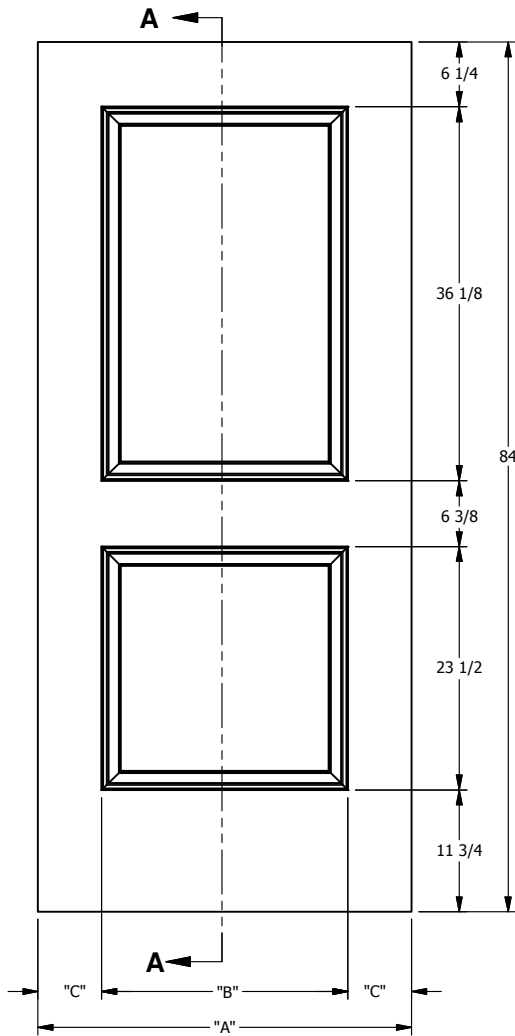

Position du bloc de poignée
Dessin / vue intérieure de la porte

Profil du panneau :
Moulure en quart de rond



DIMENSIONS				
Dimension des portes	"A"	"B"	"C"	"D"
3'-0" x 7'-0"	36"	23 3/4"	6 1/8"	3"
2'-10" x 7'-0"	34"	23 3/4"	5 1/8"	3"
2'-8" x 7'-0"	32"	21 11/16"	5 5/32"	3"
2'-6" x 7'-0"	30"	19 11/16"	5 5/32"	3"
2'-4" x 7'-0"	28"	17 11/16"	5 5/32"	3"
2'-2" x 7'-0"	26"	17 11/16"	4 5/32"	2 5/8"
2'-0" x 7'-0"	24"	13 11/16"	5 5/32"	3"
1'-10" x 7'-0"	22"	13 11/16"	4 5/32"	2 5/8"
1'-8" x 7'-0"	20"	11 6/16"	4 7/32"	3"
1'-6" x 7'-0"	18"	11 9/16"	3 7/32"	3"
1'-4" x 7'-0"	16"	9 9/16"	3 7/32"	2 5/8"
1'-3" x 7'-0"	15"	8 9/16"	3 7/32"	2 5/8"
1'-2" x 7'-0"	14"	7 9/16"	3 7/32"	2 3/8"
1'-0" x 7'-0"	12"	5 9/16"	3 7/32"	2 3/8"

FICHE TECHNIQUE - SPEC SHEET



Porte de Masonite / Masonite Door

Modèle / Model

CAMBRIDGE 8'

INTERMAT

PORTES, ESCALIERS ET BOISERIES

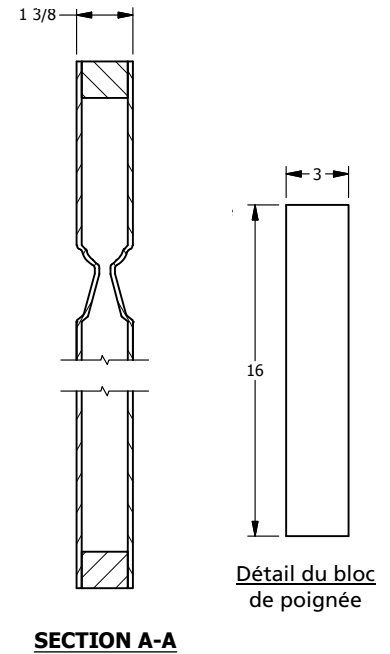
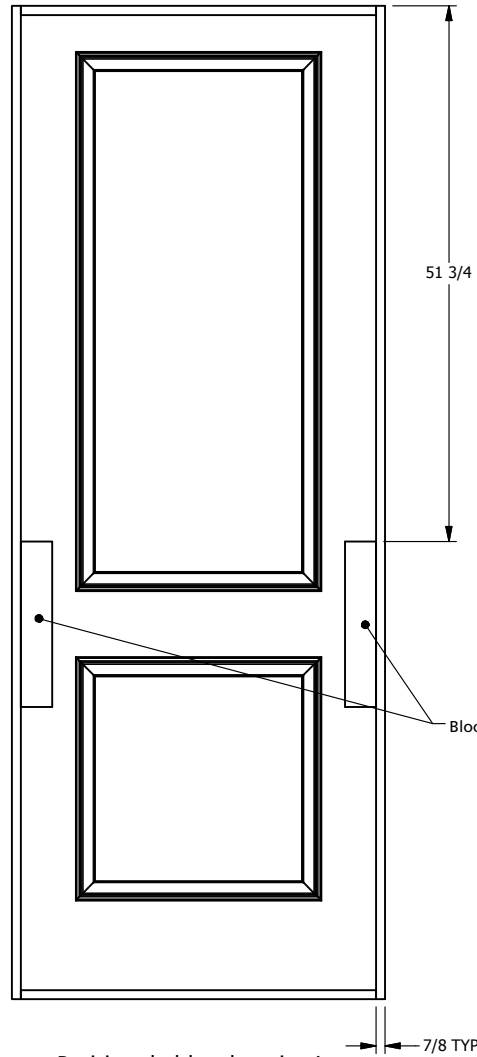
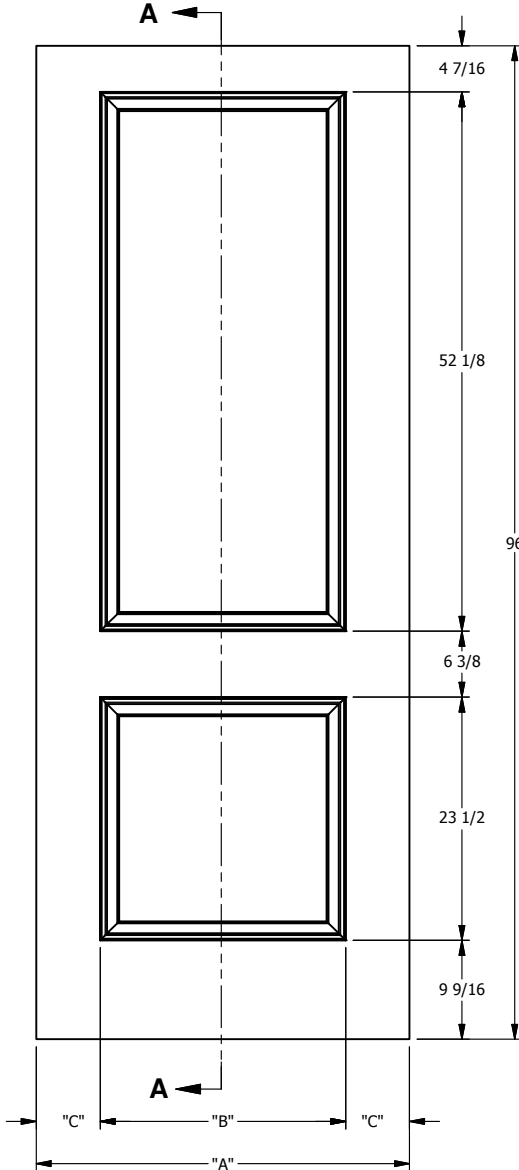

DIMENSIONS			
Dimension des portes	"A"	"B"	"C"
3'-0" x 8'-0"	36"	23 11/16"	6 5/32"
2'-10" x 8'-0"	34"	23 11/16"	5 5/32"
2'-8" x 8'-0"	32"	21 11/16"	5 5/32"
2'-6" x 8'-0"	30"	19 11/16"	5 5/32"
2'-4" x 8'-0"	28"	17 11/16"	5 5/32"
2'-2" x 8'-0"	26"	17 11/16"	4 5/32"
2'-0" x 8'-0"	24"	13 11/16"	5 5/32"
1'-10" x 8'-0"	22"	13 11/16"	4 5/32"
1'-8" x 8'-0"	20"	9 3/4"	5 1/8"
1'-6" x 8'-0"	18"	9 3/4"	4 1/8"
1'-4" x 8'-0"	16"	7"	4 1/2"
1'-3" x 8'-0"	15"	7"	4"
1'-2" x 8'-0"	14"	7"	3 1/2"
1'-0" x 8'-0"	12"	7"	2 1/2"

Profil du panneau :
Moulure en quart de rond

