

FICHE TECHNIQUE - SPEC SHEET

Quincaillerie / Hardware

Modèle / Model

ATRIX



INTERMAT

PORTES, ESCALIERS ET BOISERIES



Features:

- ▶ 45 degree latch retraction
- ▶ Heavy duty spring loaded reversible latch
- ▶ Push button auto release with privacy function
- ▶ Concealed screw mounting
- ▶ All metal construction
- ▶ Fits all standard 2 1/8" hole prepped doors
- ▶ Premium quality finishing
- ▶ Available in 2 3/8" and 2 3/4" backset
- ▶ 20 minute fire rating available
- ▶ Can be used with 1 3/8" and 1 3/4" thick doors
- ▶ Lifetime mechanical and finish warranty

Finishes:

SATIN CHROME
POLISHED CHROME
SC / PC



SATIN NICKEL
POLISHED NICKEL
SN / PN



FICHE TECHNIQUE - SPEC SHEET



Quincaillerie / Hardware

Modèle / Model

ATRIX

INTERMAT

PORTES, ESCALIERS ET BOISERIES

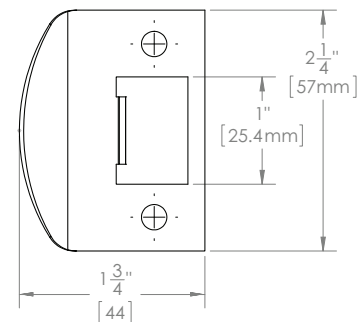
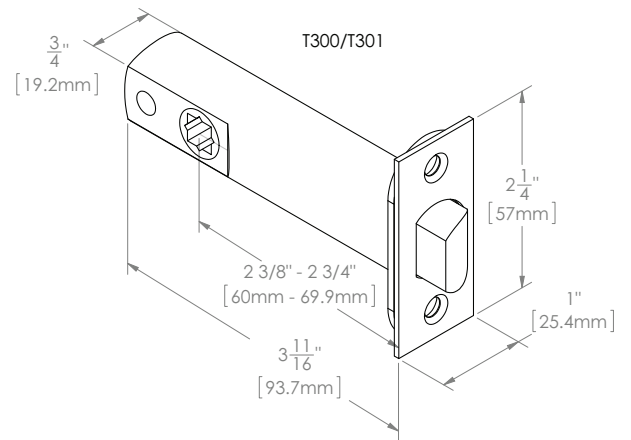
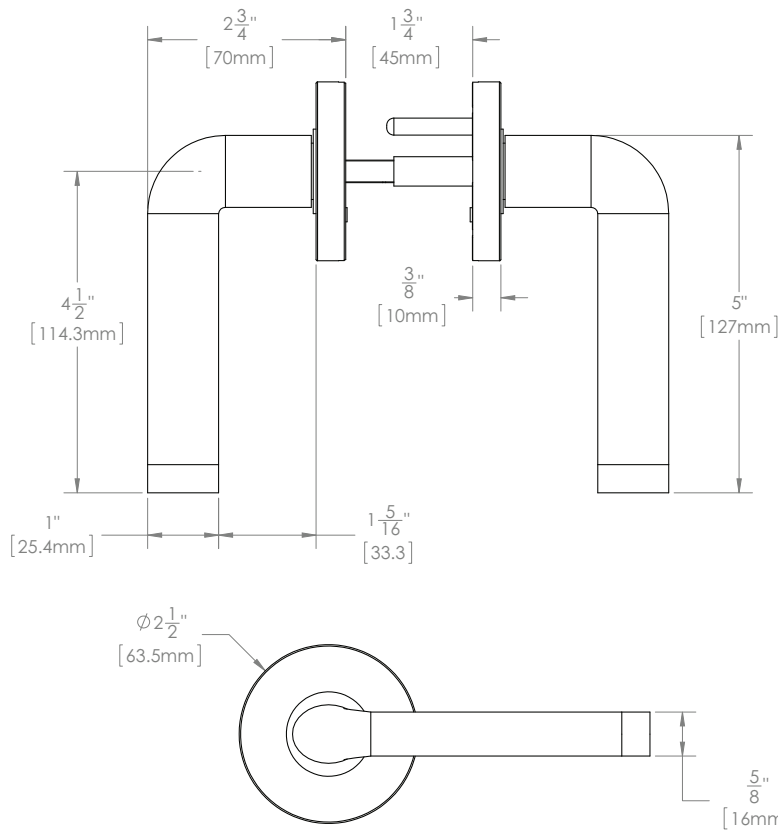

FUNCTION	BACKSET	SATIN CHROME / POLISHED CHROME SC / PC	SATIN NICKEL / POLISHED NICKEL SN / PN
PASSAGE	2 3/8" BS	LO36R21-T300-SC/PC	LO36R21-T300-SN/PN
PASSAGE	2 3/4" BS	LO36R21-T301-SC/PC	LO36R21-T301-SN/PN
PRIVACY	2 3/8" BS	LO36R21-T340-SC/PC	LO36R21-T340-SN/PN
PRIVACY	2 3/4" BS	LO36R21-T341-SC/PC	LO36R21-T341-SN/PN
DBLD		LO36R21-D390-SC/PC	LO36R21-D390-SN/PN
SGLD		LO36R21-D385-SC/PC	LO36R21-D385-SN/PN